



Automatic espresso coffee machine

Model

Modular CAPPUCCINO

Type: CAP001B

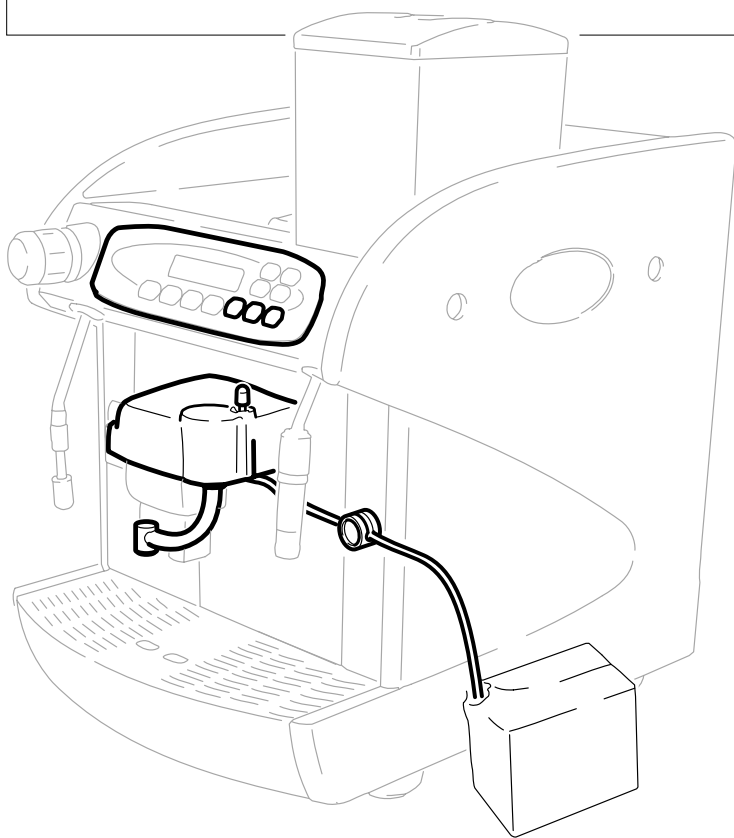

USO E MANUTENZIONE

TABLE OF CONTENTS

English page 10 ÷ 14

1 - MANUAL INTRODUCTION	10	5 - USING THE CAPPUCCINATORE	11
1.1 Foreword	10	5.1 Warnings	11
1.2 Symbols Used	10	5.2 Coffee with a dash of milk dispensing	12
2 - MACHINE INFORMATION	10	5.3 Cappuccino dispensing	12
2.1 Intended use of machine	10	5.4 Hot milk dispensing	12
3 - SAFETY	10	5.5 Programming dispenser keys	12
3.1 General safety regulations	10	5.6 Cream adjustment	13
3.2 Operator requirements	10	5.7 Display messages	13
4 - DESCRIPTION OF CONTROLS AND TOOLS	11	6 - MAINTENANCE	13
4.1 Controls	11	6.1 Foreword	13
4.2 Cappuccino dispensing unit	11	6.2 Cleaning the CAPPUCCINATORE	13
		6.2.1 Cappuccino dispensing unit	13

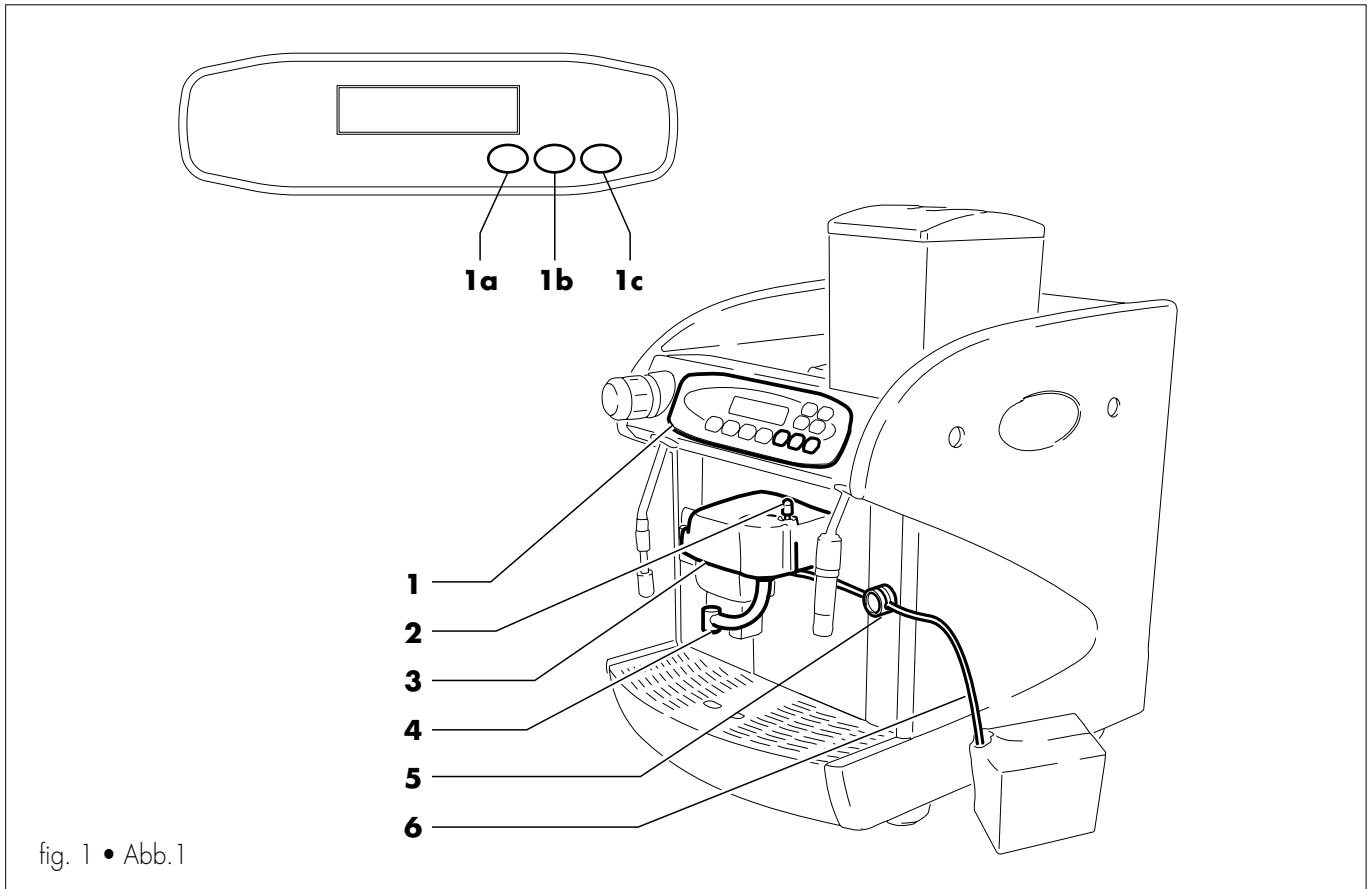

fig. 1 • Abb.1

PARTI PRINCIPALI

It

- 1 Pannello comandi cappuccinatore
- 1a Tasto caffè macchiato
- 1b Tasto cappuccino
- 1c Tasto latte caldo
- 2 Spillo di regolazione
- 3 Copertura erogatore
- 4 Tubo erogatore
- 5 Pinza blocca tubo
- 6 Tubo di aspirazione latte

MAIN PARTS

En

- 1 Cappuccino device control panel
- 1a Coffee with a dash of milk key
- 1b Cappuccino key
- 1c Hot milk key
- 2 Adjusting pin
- 3 Dispensing unit cover
- 4 Dispensing spout
- 5 Retaining clip for milk supply tube
- 6 Milk supply tube

HAUPTELEMENTE

De

- 1 Bedienungsfeld des Cappuccinatore
- 1a Taste Kaffee mit einem Schuß Milch
- 1b Taste Cappuccino
- 1c Taste heiße Milch
- 2 Einstellnadel zur Milchaufschäumung
- 3 Abdeckung Brühgruppe
- 4 Auslaufrohr
- 5 Schlauchklemme
- 6 Milchansaugschlauch

PARTIES PRINCIPALES

Fr

- 1 Tableau de commande du dispositif à café crème (cappuccinatore)
- 1a Touche café avec une goutte de lait
- 1b Touche café crème
- 1c Touche lait chaud
- 2 Pointeau de réglage
- 3 Carter distributeur
- 4 Tuyau de distribution
- 5 Pince serre-tuyau
- 6 Tuyau d'aspiration lait

PARTES PRINCIPALES

Sp

- 1 Panel de mandos dispositivo preparación café con leche
- 1a Tecla café cortado
- 1b Tecla cappuccino
- 1c Tecla leche caliente
- 2 Mando regulación crema
- 3 Protección salida café
- 4 Tubo de salida
- 5 Pinza de bloqueo tubo
- 6 Tubo de aspiración leche

PARTES PRINCIPAIS

Pt

- 1 Painel de comandos "cappuccinatore"
- 1a Tecla café garoto
- 1b Tecla "cappuccino"
- 1c Tecla leite quente
- 2 Agulha de regulação
- 3 Cobertura grupo de distribuição
- 4 Tubo de distribuição
- 5 Pinça trava tubo
- 6 Tubo de aspiração do leite

BELANGRIJKSTE ONDERDELEN

Nl

- 1 Bedieningspaneel cappuccinobereider
- 1a Toets koffie met melk
- 1b Toets cappuccino
- 1c Toets warme melk
- 2 Afstelnaald voor schuim
- 3 Afdekking schenkinrichting
- 4 Schenkleiding
- 5 Buislem
- 6 Melk-aanzuigbuisje

1 MANUAL INTRODUCTION

1.1 Foreword

Important

This manual is an integral part of the LUXE kit of the MODULAR machine, and regards the CAPPUCCINO model. It should therefore be issued with the Instruction and Maintenance booklet for the MODULAR LUXE E COFFE machine.

The aim of this manual is to provide all instructions and maintenance information necessary (procedures within user competence) for this model.

Both this manual and the MODULAR machine Instruction and Maintenance manual should be read before using the cappuccino device CAPPUCCINATORE, to ensure a good working knowledge of the equipment.

Manufacturer: **Cosmec S.p.A.**
Via Panigali, 39, 40041 GAGGIO MONTANO (BO)

This manual should be carefully kept near the CAPPUCCINATORE at all times, even when the machine changes hands. Should the manual be damaged or lost, apply immediately to an AUTHORIZED service centre for a copy.

1.2 Symbols Used

Various warnings are included in this manual to highlight the different levels of danger or competence.



Danger

This is used to indicate dangerous situations for CAPPUCCINATORE users and for the machine itself.



Maintenance Technician

This indicates the procedures which should only be carried out by the specialised maintenance personnel.

Important

Indicates procedures which should be carried out in order to maintain the CAPPUCCINATORE in good working order.

2. MACHINE INFORMATION

2.1 Intended use of machine

The fully automatic and programmable CAPPUCCINATORE produces:

- drinks with milk and freshly ground coffee;
- hot milk.

Important

In case of incorrect usage the guarantee is void and the manufacturer declines all responsibility for damage to persons and/or objects.

The following are considered to be incorrect uses:

- any use other than that described and/or using different techniques to those indicated herein;
- any modifications to the CAPPUCCINATORE which contrasts with the indications herein;
- any use following tampering with components and/or modifications of safety devices.

3. SAFETY

3.1 General safety regulations

- Read this manual carefully before using the machine.
- Deactivation of the safety devices installed in the CAPPUCCINATORE is strictly prohibited.
- For cleaning procedures the main switch or all-pole switch must be in the "0" position or the machine unplugged from the power source.
- Do not independently modify any parts of the CAPPUCCINATORE: failure to comply with this specification will result in annulment of manufacturer responsibility.
- Do not spray or splash CAPPUCCINATORE with water.

3.2 Operator requirements

For safety reasons two types of operators are required, with different capacities:

Maintenance technician

Person authorised to install, set up, regulate and generally maintain the CAPPUCCINATORE.

User

Person authorised exclusively to operate and oversee the CAPPUCCINATORE. The user may switch on the CAPPUCCINATORE, regulate the working parameters, stop the device and load the coffee beans.

In case of any malfunction of the CAPPUCCINATORE the user must request the intervention of the maintenance technician.



Danger

The user must not carry out procedures indicated in this manual as the specific responsibility of the maintenance technician.

4 - DESCRIPTION OF CONTROLS AND TOOLS



Important

The CAPPUCCINATORE is supplied with dispensing buttons pre-programmed to standard settings (see Fig. 1).

4.1 Controls

The "CAPPUCCINO" model is set up with the following controls (see fig. 1):



Coffee with a dash of milk key (Fig. 1, 1a)

(See "5.2 Coffee with a dash of milk dispensing")
Programmable (See "5.5 Programming dispenser keys")



Cappuccino key (Fig. 1, 1b)

(See "5.3 Cappuccino dispensing")
Programmable (See "5.5 Programming dispenser keys")



Hot milk key (Fig. 1, 1c)

(See "5.4 Hot milk dispensing")
Programmable (See "5.5 Programming dispenser keys")



Froth adjusting pin (Fig. 1, 2)

Vertical position can be manually adjusted (See "5.6 Froth adjustment")

Display control panel

(See Instruction and Maintenance booklet for MODULAR machine)

4.2 Cappuccino dispensing unit

The cappuccino dispensing unit (fig. 2) consists of:

- milk supply tube (fig. 2, 6)
- retaining clip for milk supply tube (fig. 2, 5)

- cappuccino device casing (fig. 2, 8)
- pin for regulation of froth quality (fig. 2, 2)
- adjustable dispensing spout (fig. 2, 4)

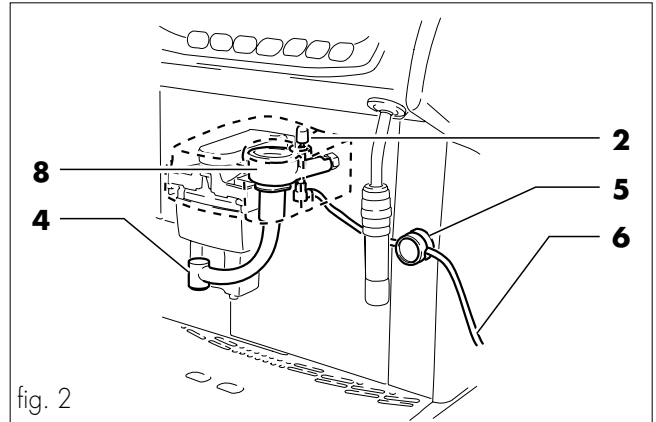



fig. 2

5 - USING THE CAPPUCCINATORE

5.1 Warnings

- Before daily start up of the CAPPUCCINATORE carry out the following procedures:
 - remove, clean and reinsert the pin regulating froth quality. Failure to reinsert the pin in the hole will prevent siphoning of milk from the container.
 - Insert free end of milk supply tube into container.
 - insert the milk supply tube in the retaining clip. Never remove the milk supply tube from the clip during use of the cappuccino device.
- Each time the CAPPUCCINATORE controls are activated, the machine carries out an automatic cycle which consists of:
 - internal discharge of condensation inside spouts;
 - siphoning of milk;
 - drink dispensing;
 - steam cleaning of spout.
- The milk used in the CAPPUCCINATORE must be kept in a refrigerator and must never be left outside the refrigerator for longer than 30 minutes.
- If the CAPPUCCINATORE is not used for more than an hour, carry out a cleaning cycle of the spouts before re-using. To clean the spouts:
 - immerse the milk supply tube in a container of water;
 - press the milk key ;
 - wait until the water has been dispensed.

PLEASE NOTE: Do not use hot water.

5.2 Coffee with a dash of milk dispensing

This drink consists of freshly ground and freshly brewed coffee dispensed by the coffee dispensing unit, to which a dash of warm milk is added by the cappuccino dispensing unit.

- Insert the milk supply tube (fig. 1, 6) into the milk container.
- Press the  key.
"COFFEE WITH A DASH OF MILK" will appear on the display.

During the dispensing process "PREBREWING" will appear on the display, if activated by the menu (see the Instruction and Maintenance manual of the MODULAR machine), while to the side of this an icon will appear showing a container being filled.

When dispensing finishes "READY FOR USE" will appear on the display.

5.3 Cappuccino dispensing

This drink consists of frothed milk dispensed by the CAPPUCCINATORE dispensing unit to which freshly ground and freshly brewed coffee is added by the coffee dispensing unit.

- Insert the milk supply tube (fig. 1, 6) into the milk container.
- Press the  key.
"CAPPUCCINO" will appear on the display;
- Regulate the quality of froth to be dispensed (see 5.1 Froth regulation) using the pin (fig. 1, 2).

During the dispensing process "PREBREWING" will appear on the display, if activated by the menu (see the Instruction and Maintenance manual of the MODULAR machine), while to the side of this an icon will appear showing a container being filled.

When dispensing finishes "READY FOR USE" will appear on the display.

5.4 Hot milk dispensing

This drink consists only of hot milk dispensed by the CAPPUCCINATORE dispensing unit.



- Insert the milk supply tube (fig. 1, 6) into the milk container.
- Press the  key.
"HOT MILK" will appear on the display;
- Regulate the quality of froth to be dispensed (see 5.1 Froth regulation) using the pin (fig. 1, 2).



During the dispensing process an icon will appear showing a

container being filled.



When dispensing finishes "READY FOR USE" will appear on the display.

5.5 Programming dispenser keys



All the dispensing keys ,  and  have a self-instructing memory. Once programmed they will dispense the same quantity of the drink each time they are activated.

To programme (or re-programme) the  and  keys, set the dosage of coffee and milk in the drink independently, using the following two procedures.







To programme (or re-programme) the  or  keys:

- Switch on the machine;
- prepare the machine for use;
- place a container under the dispensing spout (fig. 1, 4);
- press and continue to press (for more than 4 seconds) the  or  key.

PROGRAMMING COFFEE WITH A DASH OF MILK or PROGRAMMING CAPPUCCINO will appear on the display.
The machine will carry out a grinding cycle and dispense the coffee.



- Release the  or  key when the desired quantity of coffee has been dispensed. This quantity is now automatically memorised.

To programme the milk portion:

- press and continue to press (for more than 4 seconds) the  key.
PROGRAMMING MILK will appear on the display.
- Release the  key.
- press and continue to press (for more than 4 seconds) the  or  key.
The CAPPUCCINATORE will discharge the condensation in the spouts, take the milk and dispense it into the container.
- Release the  or  key.
The CAPPUCCINATORE will discharge steam from the spout.

Activate the keys briefly (less than 1 second) to obtain the programmed drink.

To programme (or re-programme) the  key:

- press and continue to press (for more than 4 seconds) the  key.
PROGRAMMING MILK will appear on the display.
- Release the  key.
- press and continue to press the  key.

The CAPPUCCINATORE will discharge the condensation in the spouts, take the milk and dispense it into the container.

- Release the  key to automatically memorise the quantity of milk dispensed; the CAPPUCCINATORE will discharge steam from the spout.

Activate the keys briefly (less than 1 second) to obtain the programmed quantity.

Important

The programmed data settings remain in the machine memory even when there is no electrical power.

5.6 Froth adjustment

The quality of froth in the drinks is proportional to the vertical position of the pin above the hole (see fig. 3). To obtain a large quantity of froth raise the pin, and lower it to obtain a small quantity (see fig. 3). Never remove the pin or completely insert it into the hole.

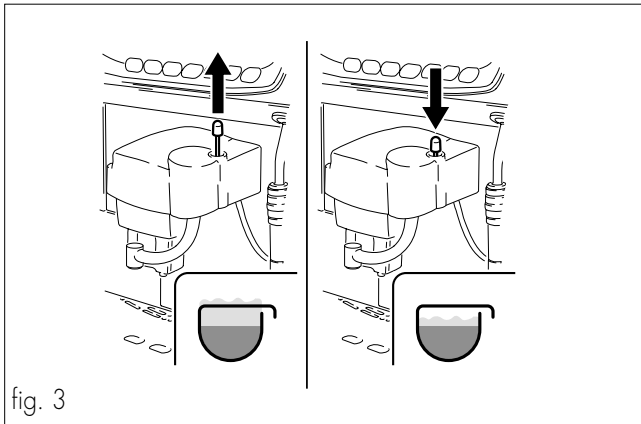

fig. 3

5.7 Display messages

On the machine display a series of messages are shown other than those already described (see Instruction and Maintenance booklet for MODULAR machine).

WATER SUPPLY - PRESS KEY \wedge : this message appears when the machine detects absence of water during drink dispensing.

PROGRAMMING: appears when programming the machine (see "6.14 Functions programmable from the menu" - see Instruction and Maintenance booklet for MODULAR machine).

PLEASE NOTE: The visual display messages are accompanied by an intermittent beeping sound.

6 - MAINTENANCE

6.1 Foreword

Danger

Before carrying out maintenance and/or cleaning procedures, disconnect the electrical power supply using the main switch (see Instruction and Maintenance booklet for MODULAR machine) and the all-pole switch (or by unplugging) and wait for the machine to cool down.

- Non-removable components should only be cleaned with cold or tepid water (unless otherwise specified) using non-abrasive sponges and damp cloths.
- Do not spray water directly onto the machine.
- All the parts to be cleaned are easily accessible and do not require special equipment.
- Regular cleaning and maintenance will preserve the machine's efficient working conditions for a longer period and guarantee conformity with hygiene standards.

Danger

In case of malfunctions normally signalled on the display, switch off the machine immediately, disconnect the power supply using the all-pole switch or by unplugging, and contact the nearest service centre.

6.2 Cleaning the CAPPUCCINATORE

Danger

Do not carry out any cleaning procedures on the cappuccino device when the machine is on standby.

Cleaning should be carried out after each use of the CAPPUCCINATORE to avoid drying of milk residue.

All removable components must be washed and rinsed in running water.

Important

Never wash the components in dishwashing machines.

6.2.1 Cappuccino dispensing unit

To clean the cappuccino dispensing unit components individually (fig. 4) the following must be removed:

- the upper casing (fig. 4, 3), removing it upwards;
- the froth adjusting pin (fig. 4, 2);
- the air diffuser (fig. 4, 7) from the cappuccino device casing, in an upwards direction;
- the cappuccino device casing (fig. 4, 8) pulling it towards you;

- the connection fitting (fig.4, 9) from the milk supply tube to the cappuccino device casing;
- the adjustable dispensing spout (fig.4,4);
- the milk supply tube (fig.4, 6).

Important

For all machine maintenance refer to the Instruction and Maintenance booklet for MODULAR machine.

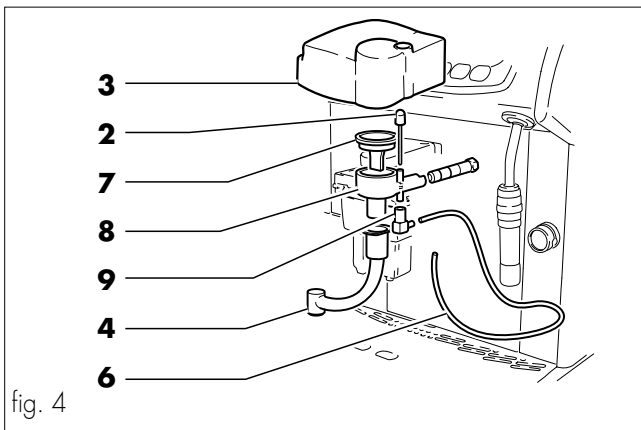

fig. 4

